

2-veis kuleventil for PN10, PN16, ANSI 150

Rustfritt stål, fullt løp, universal wafertype

AVS

725000

Montering: Mellom flenser
Manøver: Håndspak / 0-90° aktuator
Nominell diameter: Fullt løp DN25 – DN100
Trykkklasse: PN20 , **Temperatur:** -20 +160°C



Limiti di temperatura: -20° +160° - Temperature range: -20° +160°

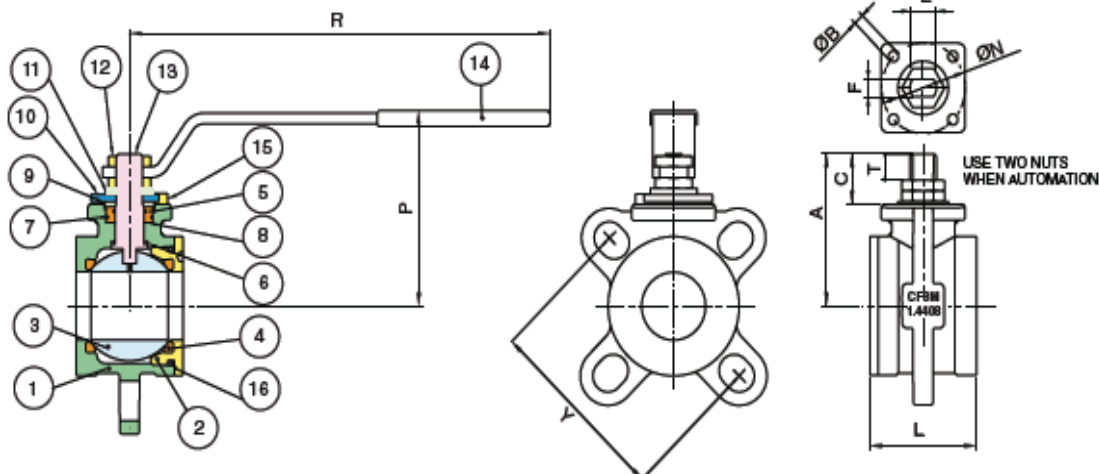

POS.	DENOMINAZIONE	PART NAME	MATERIALE - MATERIALS	NP
1	CORPO	BODY	A351 - CF8M	1
2	GHIERA	END CONNECTION	A182 - F316	1
3	SFERA	BALL	A182 - F316	1
4	GUARNIZIONE SFERA	BALL SEAT	P.T.F.E.	2
5	O-RING	O-RING	FKM (VITON®)	1
6	RONDELLA AASTA	THRUST WASHER	P.T.F.E.	1
7	O-RING	RING	FKM (VITON®)	1
8	GUARNIZIONE ASTA	STEM SEAT	P.T.F.E.	1
9	BUSSOLA PREMIGUARNIZIONE	PACKING GLAND	A182 - F316	1
10	RONDELLA MEZZOGIRO	END STOP	CARBON STEEL	1
11	MOLLA A TAZZA	SPRING WASHER	CARBON STEEL	2
12	DADO	NUT	CARBON STEEL	2
13	ASTA	STEM	A182 - F316	1
14	LEVA	HANDLE	CARBON STEEL	1
15	VITE	SCREW	CARBON STEEL	2
16	O-RING	O-RING	FKM (VITON®)	1

MISURA SIZE	DN	Y	L	R	P	A	C	T	E	F	ØN	B	Kv	PN	Kg
1"	25	PN10 - PN16 - ANSI150	48	174	91	71,5	23	10,5	M12	8	42	M5	43	20	1,30
1 1/4"	32	PN10 - PN16 - ANSI150	54	174	95	75	23	10,5	M12	8	42	M5	89	20	1,85
1 1/2"	40	PN10 - PN16 - ANSI150	89,5	250	110	85	28	15	M16	10	50	M6	230	20	2,15
2"	50	PN10 - PN16 - ANSI150	82	250	119	88,5	28	15	M16	10	50	M6	265	20	3,75
2 1/2"	65	PN10 - PN16 - ANSI150	103	321	145	121,5	33,5	18	M20	14	70	M8	540	20	7,35
3"	80	PN10 - PN16 - ANSI150	122	321	154	131	33,5	18	M20	14	70	M8	873	20	10,30
4"	100	PN10 - PN16 - ANSI150	152	321	187	144	33,5	18	M20	14	70	M8	1390	20	16,00

SKRUER OG PINNEBOLTER FOR MONTASJE MELLOM FLENSER

MISURA SIZE	PN16			ANSI150		
	VITE - SCREW	TIRANTE - STAY BOLT	N°	VITE - SCREW	TIRANTE - STAY BOLT	N°
DN25	M12X100	M12X110	4	M14X100	M14X110	4
DN32	M16X110	M16X130	4	M14X100	M14X130	4
DN40	M16X120	M16X140	4	M14X130	M14X140	4
DN50	M16X140	M16X160	4	M18X140	M18X160	4
DN65	M16X160	M16X180	4/8	M18X170	M18X190	4
DN80	M16X180	M16X200	8	M16X190	M16X210	4
DN100	M16X210	M16X230	8	M18X220	M18X240	4



MONTASJE AV VENTILTYPEN MELLOM FLENSER

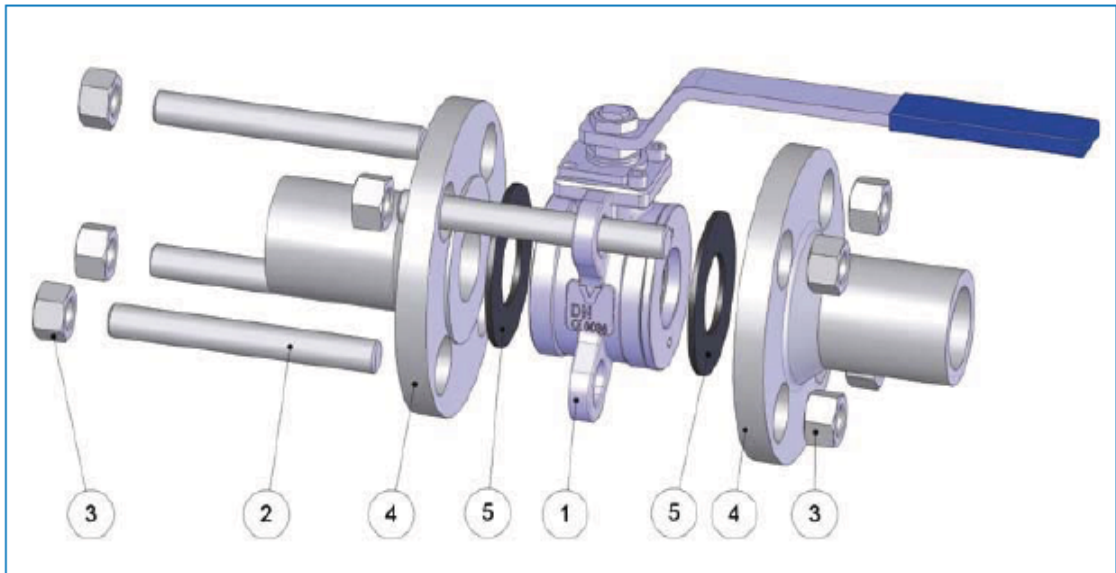

POS.	DENOMINAZIONE	PART NAME
1	VALVOLA A SFERA	BALL VALVE
2	VITE	SCREW
3	DADO	NUT
4	FLANGIA	END CONNECTION
5	GUARNIZIONE TENUTA	TIGHTENING SEAL

VENTILMONTASJE for dimensjon DN25 til DN80

PN10/16 flenser:

Sett inn de to øverste skruer og la ventilen henge på skruene , Sett inn de to nederste skruene monter muttere og trekk til.

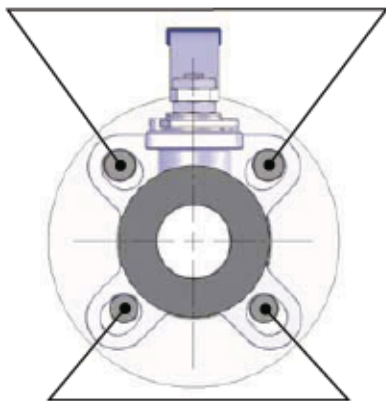

ANSI150 flenser:

Sett inn de to nederste skruer og la ventilen henge på skruene , Sett inn de to øverste skruene monter muttere og trekk til.

VENTILMONTASJE for dimensjon DN100

ANSI 150 flenser:

Sett inn de to øverste skruer og la ventilen henge på skruene , Sett inn de to nederste skruene monter muttere og trekk til.

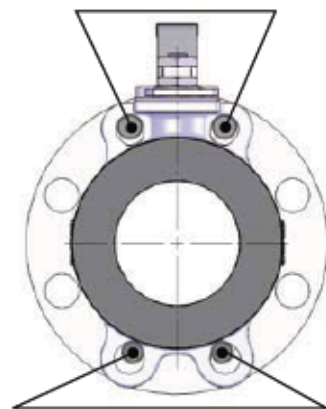

PN10/16 flenser:

Sett inn de to nederste skruer og la ventilen henge på skruene , Sett inn de to øverste skruene monter muttere og trekk til.

Bestilling til Tlf. 64860430 eller E-post: postmaster@avs.no